



## Manual controls - Screwjacks

With a mechanically irreversible action the Screwjack system may be utilised for heavy application where its design enables a considerable reduction in load on both the window-gear and the operator handle.

Incorporating the ability to sustain a load at the point of application, the screwjack will effect secure tight closing.

For all fallback bottom hinged installations, it is essential that the window

manufacturer be asked to provide side checks to the vent.

It is also necessary to ensure that a minimum 40 mm headroom is available above the vent to accommodate this unit.

Colours:

White and brown

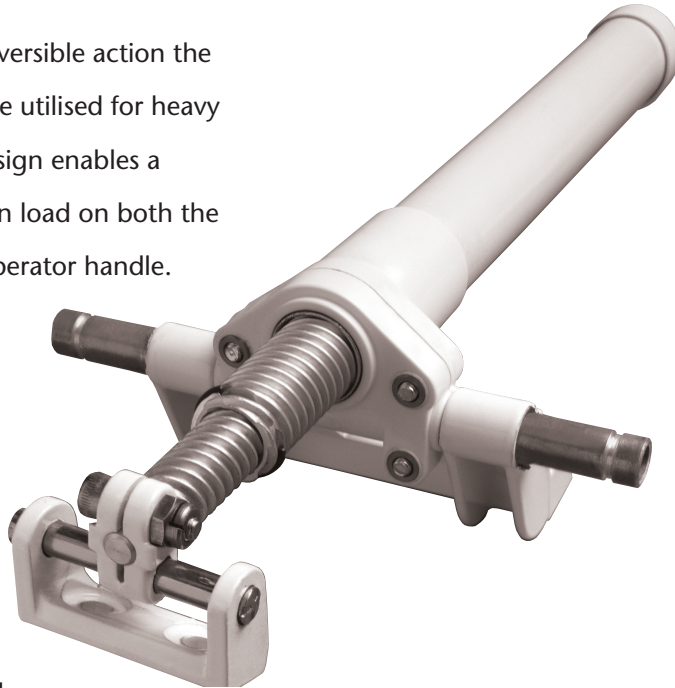

### Key Features

- Screwjack will effect a secure tight closing.
- No-ferrous aluminium construction guarantees maximum reliability and maximum working life.

### Part Numbers

Part No. 138600

Thrust & Traction Force 22kg

Opening vent 380mm



TECHNICAL SPECIFICATION - SCREWJACKS

